

**Appendix 10 - Nitzana Border Crossing
Cargo/Vehicle Inspection site**

**Guidelines for supply and installation
responsibilities between the construction
Company and Nuctech**

21/08/2023

Overview

The infrastructure construction works for installing NUCTECH™ Relocatable Cargo/Vehicle Inspection System in Nitzana are mainly consisted of the following physical buildings:

A, Radiography building for running scanner and shielding X-ray.

B, Image operator room for operating the scanner, safety control, and analyzing radiographic images.

C, Computer server room for running the computer server of the X-ray system.

D, Site manager room.

E, Electronic room for installing UPS and Panel of X-ray system.

F, Electricity room for power supply of X-ray system.

G, Spare parts storage and technician room

H, Driver's waiting room next to the radiography building.

I, Entry control room.

J, Re-check office room.

K, Driver's waiting room next to recheck building.

L, Check-out room at the exit gate.

Preliminary General Layout Concept from the Customs:



Description of the work interface

Work interfaces between infrastructure works of NUCTECH™ Relocatable Cargo/Vehicle Inspection System and installation works of Nuctech Company include, but may not limit to:

A, Radiography building for running scanner and shielding X-ray.

Construction Company	Nuctech
<ul style="list-style-type: none"> • Scanning tunnel roof with shielding wall; • Installation of shielding doors; • Installation of Ventilation, illumination, fire protection,thunder, lightening-protection; • Shielding door rails supply and installation; • Power sockets, cable trays, and conduits supply and installation; • Floor to accommodate the three rail tracks and traffic lane, with drainage capability; • Pipe connection to electronic room; • Supply and install pre-embedded anchorbolts for fixing rail tracks of scanner and shielding doors, with nuts, gaskets and, washers; • Supply and install steel plates for leveling the rail tracks of scanner andshielding doors. • Supply and install pre-embedded steel plates for fixing shielding doors; • Metal guiding tubes for traffic. • Earthing system, including thunder lightening protection. • Earthing connection for rail tracks and dragging chain. • Entrance shielding beam for height limitation. 	<ul style="list-style-type: none"> • Installation of Gantry; • Rail tracks supply and installation (lining, leveling, fixing, and welding); • Installation of CCTV cameras, Public Address, Emergency stops, Emergency stop pull-cords, Warning lights; • Cable connection of X-ray system, including all the IT/VLV works. • Installation of Interlock system devices including speakers and warning. • Supply and installation of shielding doors. • Supply of plans including building details (including electricity, communication and rails).

B, Image operator room for operating the scanner, safety control and analyzing radiographic images.

Construction Company	Nuctech
<ul style="list-style-type: none"> • Office room with ventilation and air-conditioning, illumination, fire protection thunder lightning-protection; • Supply of Office furniture; • Supply and installation of Power sockets and IT sockets; • Supply and installation of IT cable connecting with the switch inside the operator room; • Supply and installation of Cabling, Wiring & Termination indoor & outdoor to other buildings, communication room, etc. • Supply and installation of Earthing system, including thunder lightning protection. 	<ul style="list-style-type: none"> • Supply and installation of control and monitoring workstations (SCC-Smart control center), CCTV screen, 4 analyzing radiographic images (IAW), driver's tag reader, host of intercom, UPS. • Supply and installation of Interlock system devices including speakers and warning lights (traffic signals) with a radiation detector.

C, Computer server room for running the computer server of the X-ray system.

Construction Company	Nuctech
<ul style="list-style-type: none"> • Office room with ventilation and air-conditioning, illumination, fire protection, thunder lightning-protection; • Supply of Office furniture; • Power connection for UPS; • Supply and installation of IT cable connecting with the all X-ray system devices, except those in scanning tunnel and Nuctech Panel inside electronic room; • Supply and installation of Cables, Optic Fibers & Conduits indoor and outdoor including termination. • Supply and installation of Earthing system, including thunder lightning protection. 	<ul style="list-style-type: none"> • Supply and installation of server cabinet including its hardware.

D, Site manager room

Construction Company	Nuctech
<ul style="list-style-type: none"> • Office room with ventilation and air-conditioning, illumination, fire protection, thunder lightning-protection; • Supply of Office furniture; • Supply and Installation of Power sockets for SCC; • Supply and Installation of Network socket and IT cable connecting with the switch inside the computer server room; • Supply and Installation of Earthing system, including thunder lightning protection. 	<ul style="list-style-type: none"> • Supply and Installation of the SCC.

E, Electronic room for installing UPS and Panel of X-ray system

Construction Company	Nuctech
<ul style="list-style-type: none"> • Office room with ventilation and air-conditioning, illumination, fire protection, thunder lightning-protection; • 60KVA power connection for UPS; • Cable channel between UPS and Nuctech Panel. • Cable channel to scanning tunnel. • Cable channel to operator room. • Earthing system, including thunder lightning protection. • Work includes cabling and installation. 	<ul style="list-style-type: none"> • Supply and Installation of UPS for Gantry and Nuctech Panel. • Cable connection between UPS for Gantry and Nuctech Panel. • Cable connection between Nuctech Panel and Gantry, shielding doors, and other system devices inside the scanning tunnel. • Cable connection between Nuctech Panel and sever cabinet in server room.

F, Electricity room.

Construction Company	Nuctech
<ul style="list-style-type: none"> • 60KVA power supply for Nuctech UPS inside electronic room. • Power supply for all other system devices. • Earthing system, including thunder lightning protection. • Work includes cabling and installation. 	

G, Spare parts storage and technician room

Construction Company	Nuctech
<ul style="list-style-type: none"> • Room with ventilation and air-conditioning, illumination, fire protection, thunder lightning-protection; • Supply of Office furniture; • Supply of Shelves. • Supply and Installation of Power sockets for computer workstation; • Supply and Installation of Network socket and IT cable connecting with the switch inside the computer server room; • Supply and Installation of Earthing system, including thunder-lightning protection 	<ul style="list-style-type: none"> • Installation of the computer workstation.

H, Driver's waiting room next to the radiography building.

Construction Company	Nuctech
<ul style="list-style-type: none"> • Room with ventilation and air-conditioning, illumination, fire protection, thunder lightning-protection; • Supply of Furniture; • Supply and Installation of Power sockets. • Supply and Installation of Cable channel to the computer server room. • Supply and Installation of Earthing system, including thunder-lightning protection. 	<ul style="list-style-type: none"> • Installation of intercom and Public Address. • Installation of Interlock system devices including speakers and warning lights (traffic signals) • Driver card reader • Signage

I, Entry control room

Construction Company	Nuctech
<ul style="list-style-type: none"> • Cabins with ventilation and air-conditioning, illumination, fire protection, thunder lightning-protection; • Supply of Office furniture; • Power sockets and IT sockets; • Supply and Installation of Network socket and IT cable connecting with the switch inside the computer server room; • Supply and Installation of Cable trough along the wall. • Supply and Installation of Earthing system, including thunder-lightning protection. • Supply and Installation of PA • Supply and Installation of communication cabinet, electrical cabinet, arm barriers and cameras. 	<ul style="list-style-type: none"> • Installation of the SCC workstation and its UPS, Driver's tag printer, Document scanner, Network switches, PA, and intercom • LPR

J, Recheck office room.

Construction Company	Nuctech
<ul style="list-style-type: none"> • Office room with ventilation and air-conditioning, illumination, fire protection, thunder lightning-protection; • Supply and Installation of Office furniture; • Supply and Installation of Power sockets and IT sockets; • Supply and Installation of Network socket and IT cable connecting with the switch inside the computer server room; • Supply and Installation of Cable trough along the wall. • Supply and Installation of Earthing system, including thunder lightning protection. • Supply and Installation of PA 	<ul style="list-style-type: none"> • Installation of manual check work stations, as well as one SCC workstation, driver's tag reader, network switches, and intercom.

K, Driver's waiting room next to recheck building.

Construction Company	Nuctech
<ul style="list-style-type: none"> • Office room with ventilation and air-conditioning, illumination, fire protection, thunder lightning-protection; • Supply of Office furniture; • Supply and Installation of Power sockets; • Supply and Installation of Network socket and IT cable connecting with the switch inside the recheck office. • Supply and Installation of Earthing system, including thunder lightning protection. • Supply and Installation of PA 	<ul style="list-style-type: none"> • Installation of electronic information board.

L, Check-out room at the exit gate.

Construction Company	Nuctech
<ul style="list-style-type: none"> • Cabin with ventilation and air-conditioning, illumination, fire protection, thunder lightning-protection; • Supply of Office furniture; • Power sockets; • Network socket and IT cable connecting with the switch inside the computer server room; • Cable trough along the wall. • Supply and Installation Earthing system, including thunder lightning protection. • Supply and Installation of communication cabinet, electrical cabinet, arm barriers and cameras. 	<ul style="list-style-type: none"> • Installation of Check-out workstation and its UPS, Driver's tag reader, Network switches, PA, and intercom. • LPR.

M, Electronic information board (Electronic Signage) on site.

Construction Company	Nuctech
<ul style="list-style-type: none"> • Poles for supporting information board; • Power supply; • Communication cable connection from the computer server room to the poles. • Supply and Installation of Earthing system, including thunder-lightening protection. 	<ul style="list-style-type: none"> • Installation of the information board.

N, Traffic barrier

Construction Company	Nuctech
<ul style="list-style-type: none"> • Base of traffic barrier; • Power supply connection inside the check-in/out room; • Communication cable channel from the check-in/out room to the base. • Supply and Installation of Earthing system, including thunder-lightening protection. 	<ul style="list-style-type: none"> • Installation of traffic barrier.

O, LPR

Construction Company	Nuctech
<ul style="list-style-type: none"> • Supply and Installation Base and poles for LPR camera; • Supply and Installation Power supply; • Supply and Installation Communication cable channel; • Supply and Installation of sensor of LPR under the pavement. • Supply and Installation Earthing system, including thunder-lightening protection. 	<ul style="list-style-type: none"> • Installation of LPR.

P, Height-limitation frame

Construction Company	Nuctech
<ul style="list-style-type: none"> • Design and Supply of construction plans; • Supply and Installation of Height-limitation frame. 	<ul style="list-style-type: none"> • Supply and Installation of height limitation and warning sensors (visual and/or sound); • Connecting the sensors to the SDMS system.

Principles and guidelines of the Radiography building

A, Description of Closed Scanning Tunnel with Concrete Shielding Structure:

1. Scanning tunnel for screening two 40 ft. long containers loaded on a truck (length up to 20m) should be built up.
2. Surrounding the scanning tunnel, the outside size of which is 59m*13.95m, build a concrete shielding wall for radiation safety protection, with a thickness of 400mm (on the accelerator side) and 550mm (on the detector side), the density of which is 2.35g/mm³.
3. Top of the concrete shielding wall should be 5 meters higher above the ground and should be higher than the office building.

Layout of the concrete shielding wall:

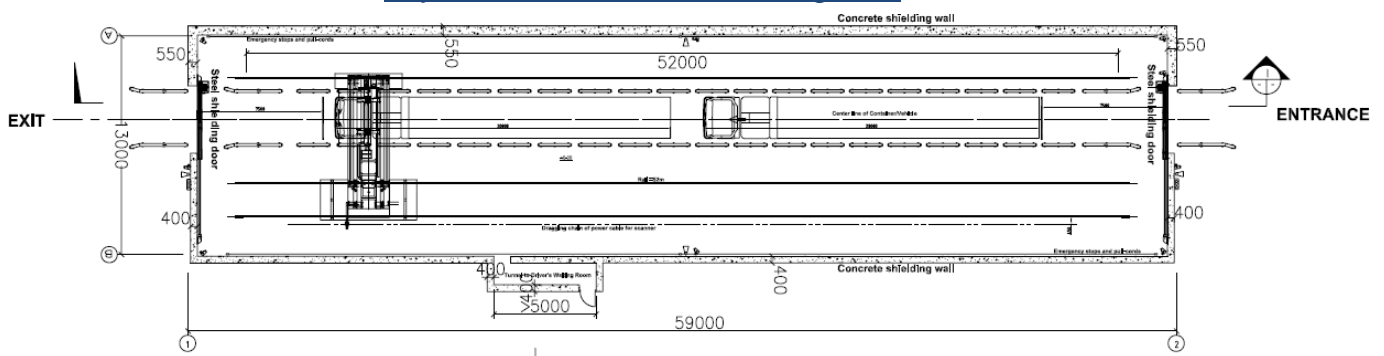

4. The joint point of wall construction should be guaranteed the equivalent thickness of the wall. Holes and gaps on the shielding wall should be prevented.
5. Height of the scanner is about 6 meters.
6. In front of the scanning tunnel, height limitation frame should be installed to prevent any damage from the scanner.
7. Facilities, including those for ventilation, power sockets of maintenance, communication, cable trough surrounding the tunnel, fire cabinet etc, are requested.
8. The scanning area shall be illuminated by efficient illumination internally and externally. Illumination to be designed with accordance to local standards.
9. Thunder lightning protection shall be built up according to local norm.
10. Maintenance outlets installed on the shielding wall, which are 3P/2P (single phase 220V, 25A, three phase 380V, 40A), are requested.
11. On the concrete wall surrounding the scanning tunnel, will equipped with CCTV cameras, Public Address, Emergency stops, Emergency stop pull-cords, Warning lights and Sirens, for radiation safety. (Except emergency stops and pull-cords, all the system devices will be installed on top of Concrete wall)

12. Along the shielding wall of the radiography building should be installed with two 100mm*75mm wiring groove, 2500mm above the ground, for Laying of communication and electricity cables of X-ray system.
13. 2*D100mm pipes is needed for connecting dragging chain in the Radiography building with Nuctech Panel in the Electronic Room. Steel wire should be put into the pipes for latterly wiring work.
14. 4*D100mm pipes is needed for connection Nuctech Panel in Electronic room with the cable trays surrounding the radiography building.
15. It should be emphasized that all stages of construction should be coordinated by construction contractor and Nuctech. Construction contractor will hand over all plans and time lines for approval at every stage these are issued. (a general remark, not only for the tunnel).
16. It should be particularly mentioned that roof closure should be coordinated with Nuctech as Nuctech will crane heavy parts into the tunnel after the walls are poured.

B, Description of Closed Scanning Tunnel with Concrete Shielding Structure:

1. Floor of the scanning tunnel should be higher than outside ground level with capability of drainage.
2. Reinforcement concrete base is required to accommodate the three rails, with same length of 52 meters for each, for running the scanner.
3. The base to accommodate the 3 rails can be of strip foundation (slab foundation for the whole area of floor of scanning hall is also recommended). Piling work will be designed to prevent any unbalanced settlements of the base according to the geological survey.
4. Concrete floor is suggested for other area of the scanning tunnel. If concrete floor is adopted but not a slab, it is better separated from the base of rails to prevent any unbalanced settlements.

Strip foundation to accommodate rail:

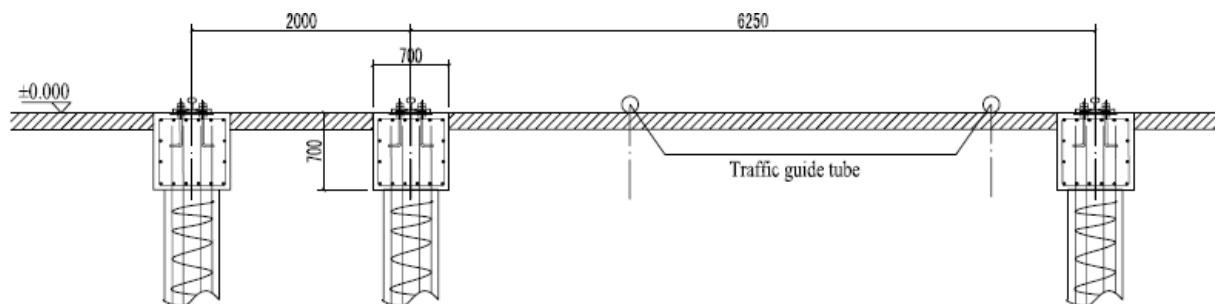

5. Traffic lane between the rails should be with adequate bearing capacity for heavy truck of 80T.
6. Metal traffic guide tubes (steel pipe) should be supplied and installed along the traffic lane, protecting the scanner from damage. The clearance distance between the tubes better no less than 3000mm. Height of tube is no less than 150mm. Indication lines for traffic lane and "STOP" should be marked on the ground.
7. Design for ground base of the rails should also according to the weight and axial weight of the scanner, and should be prevented from settlement and guarantee no relative displacement happening. The total load of the main equipment is approximately 40T. There is one pair of wheels of scanner on each line of rail. Maximum axial pressure load for each wheel is 7~11T, and the distance of the two wheels is 4300mm.

Load of the scanner:

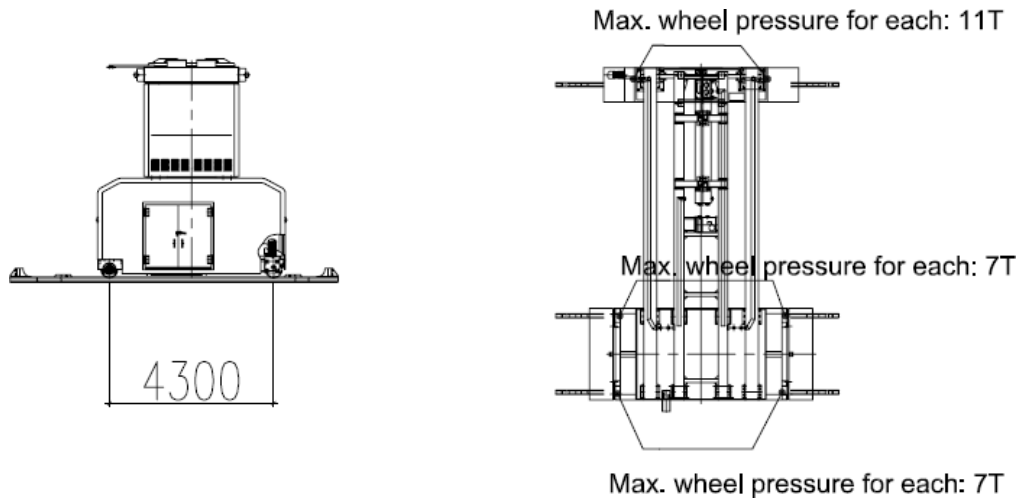

8. Anchor bolts (M20) for fixing the rails shall be pre-embedded in concrete (leveling steel plates for rail will be fixed by the anchor bolts, and then the rails will be laid on the plates and fixed by steel bolts and fastener. After the rail is installed and finish adjustment, slurry concrete will be poured as secondary pouring between the steel leveling plates and first concrete base).

Bolts should be installed, fixed and protected:

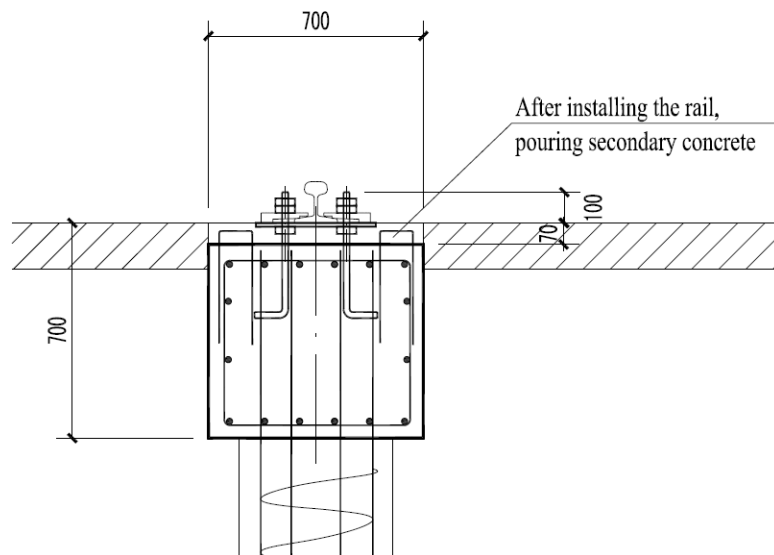

9. Dragging chain, which moving power cable and communication cables connected with scanner, will also be installed on the concrete floor, next to the accelerator side. The dragging chain itself will be supplied and installed by Nuotech.

10. 2*D100mm pipes is needed for cables connection of Nuctech Panel in Electronic room with the dragging chain installed on the floor of scanner hall. Steel wire should be put into the pipes for latterly wiring work.

11. Another 4*D100mm pipes is needed for connection Nuctech Panel in Electronic room with the cable trough surrounding the radiography building. Steel wire should be put into the pipes for latterly wiring work.

C, Description of Closed Scanning Tunnel with Concrete Shielding Structure:

1. Three rails (supplied and installed by Nuctech) on which the scanner will be moving are same type of P38 or P43, with same length of 52 meters for each. The distances between centerlines of the three rails 6250mm and 2000mm separately.

Specification of P38/P43 rail:

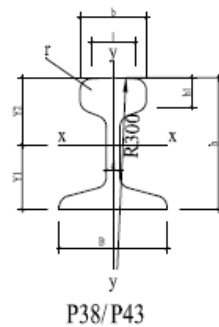

Size of rail mm	h	h1/t	b	B	l	Y1	Y2	d	r
P38	134	27.7	68	114	43.9	66.7	67.3	13.0	13
P43	140	32.4	70	114	46.0	68.5	71.5	14.5	15

Size of rail	Area of section cm ²	Moment of inertia		Section Coefficient			Weight/m kg	Standard No.
		I _x	I _y	W ₁ = $\frac{I_x}{Y_1}$	W ₂ = $\frac{I_x}{Y_2}$	W ₃ = $\frac{I_y}{b/2}$		
		cm ⁴		cm ³				
P38	49.5	1204.4	209.3	180.6	178.9	36.7	38.73	GB2585-81
P43	57.0	1489.0	260.0	217.3	208.3	45.0	44.65	GB2585-81

2. At both ends of each rail, there is a short rail for installing colliding preventing devices (stopper); the length of each short rail is 665mm, with 10mm gap from the long rail. The short rail will be welded on the pre-embedded steel plates after the installation of the stopper finished.

Layout of three lines of rail tracks:

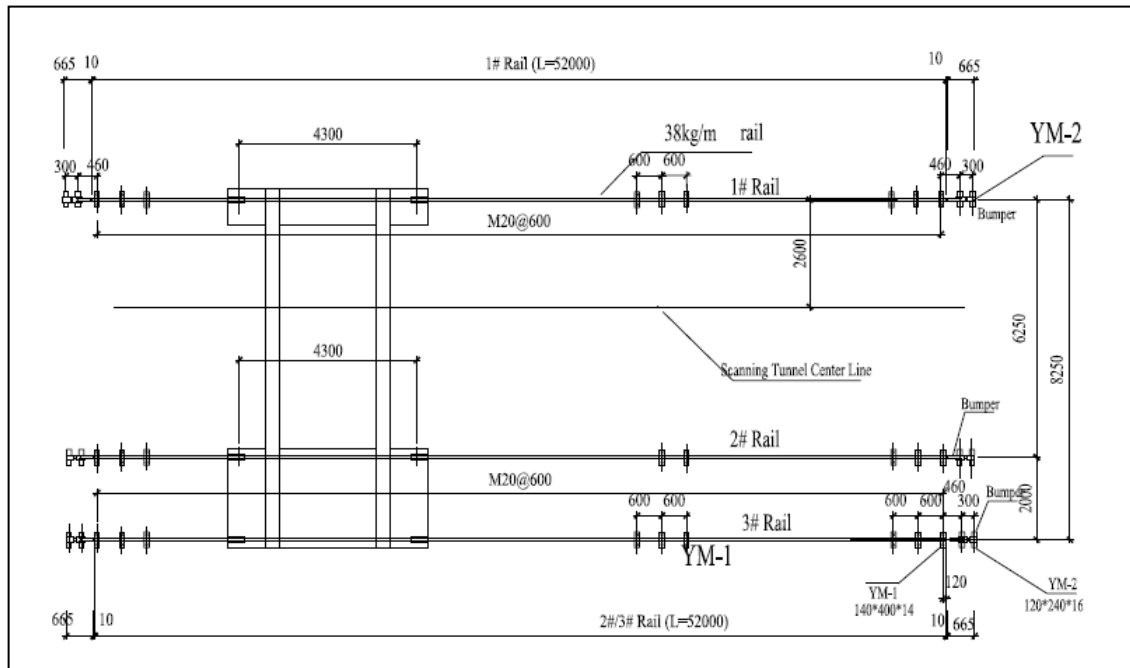

3. The joint points of each long rail will not in the same section, to prevent shaking of the scanner. The joints of the rails will be welded on top and smoothing with no twist happening. The position of the joints should be staggered with at least 1m. Rail tracks will be installed by Nuctech.
4. Using the pre-embedded M20 anchor bolts, the first step of installing the rail is to install the steel plates (140mm*400mm*14mm) for leveling at 600mm interval for adjusting the rail. After making the plates on the same level, put the rail on plates and make secondary adjustment. After checking, secondary concrete is pouring under the plates for fixing the plates.

Installation of rail:

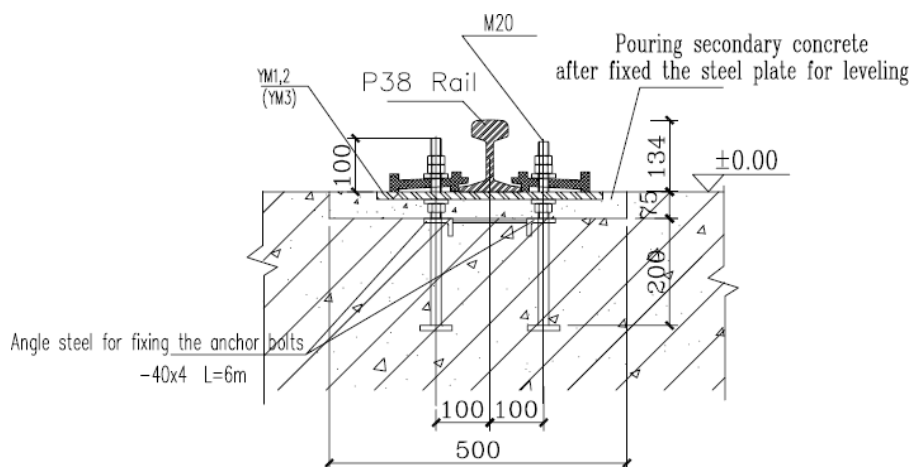

5. For each rail, the difference of linearity should be less than 2mm. For each two rails, the difference of parallel should be less than 2mm. For any 4m section, the difference of distances between each two rails should be $6250 \pm 2\text{mm}$ and $2000 \pm 3\text{mm}$. Height difference of total length of each rail should be less than 10mm. For all the three rails, the difference of the top level of each should be less than 2mm within any 4m section.

6. A grounding system with resistance less than 1Ω should be prepared independently for scanner. The THREE rails should be well connected to this earthing system, as well as the cable trough of the dragging chain.

D, Description of Shielding Doors (in the radiography tunnel):

1. Entrance and exit of the scanning tunnel will be restricted with 2 sets of metal shielding gates (effective thickness of 120mm) remotely controlled. Size of the door opening is 4.00m (W) x 5.00m (H).

Installation of rail:

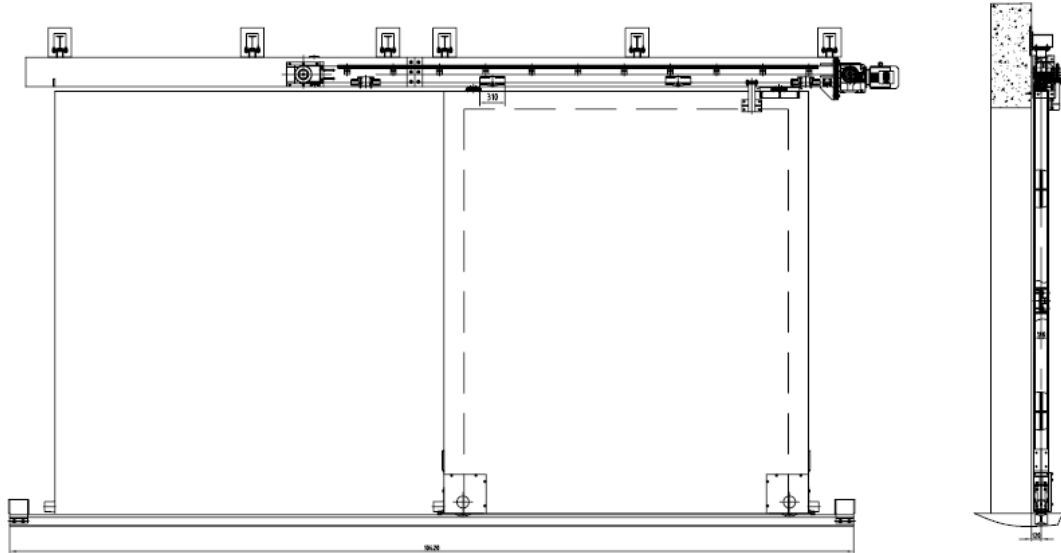

2. The shielding door (supplied by Nuctech and installed by Construction Company) should be installed inside the scanning area, fixed by pre-embedded steel plates in the upper side and running on a guide rail at bottom.
3. Total weight of each door is around **20T**.
4. Around 20KVA power supply is needed for driving the 2 sets metal gates.
5. Metal frame for traffic height limitation should be supplied and installed in front of the entrance shielding door. Traffic height limitation is 4.8m.
6. All pre-embedded items will be supplied and installed by the contractor and installations after pouring the concrete will be made by Construction Company (contractor will supply and install pre-embedded plates for fixing the doors; and anchor bolts, nuts, springs, washers for fixing the rail track under the doors). Nuctech will be reasonable for the interlock system.

Principles and guidelines for the construction of the X-ray inspection and other buildings

A, Image operator room

1. Image operator room for operating the scanner and safety control (including control and monitoring workstations, and CCTV screen) and 4 analyzing radiographic images (IAW), driver's tag reader and its workstation, that will be supplied and installed by Nuctech;
2. Host of Public Address will also be installed at operator room.
3. All system computers (supplied by Nuctech) will be equipped with a small UPS separately.
4. Air-conditioning, CO2 fire extinguishers, standard office furniture for the room should also be built up, with accordance to local standards.
5. Illumination should be according to local standards.
6. Thunder lightening protection shall be built up according to local norm.
7. Power supply for the operation room should cover all the consumptions including 15KW for the system devices inside the room.
8. Each workstation shall be staffed with 6 power outlets, 16A+2N Above every table.
9. Each workstation shall be staffed network sockets with 4 RJ45 jacks.
10. Each workstation shall be equipped with UPS.
11. The room should be equipped with surrounding cable trough for laying communication cables; specification of 150mm*50mm is suggested. The cable trough should be connecting to Computer Server room, as well as to Nuctech Panel in Electronic room.

B, Computer server room

1. Computer server room, equipped with a electronic cabinet, which including a server of the X-ray system, an interface server, a network switches, 1 UPS (5KVA), that will be supplied and installed by Nuctech, is suggested with floor space of 12sq. m.
2. The size of electronic cabinet is 1000mm*600mm*2055mm (H).
3. Lighting, independent and backed up air conditioning, CO2 fire extinguishers, standard office furniture for the room should also be built up, with accordance to local standards.
4. Illumination should be according to local standards.
5. Thunder lightening protection shall be built up according to local norm.
6. Power supply for the operation room should cover all the consumptions including 5KW for the system devices inside the room.
7. Shall be staffed with 2 power outlets, 16A, near the electronic cabinet.
8. The room should be equipped with cable trough for laying communication cables; specification of 150mm*50mm is suggested. The cable trough should be connecting to Operator room, as well as to Nuctech Panel in Electronic room. (If raised floor is used, communication cable channel may go under the floor.)

C, Site Manager room

1. A SCC workstation (supplied by Nuctech) will be installed in the site manager room.
2. All facilities should be built up, including air-conditioning, fire protection, office furniture, etc, with accordance to local standards.
3. Illumination should be according to local standards.
4. Thunder lightning protection shall be built up according to local norms.
5. The workstation shall be staffed with 6 power outlets, 16A+2N Above every table.
6. Each workstation shall be staffed network sockets with 4 RJ45 jacks.
7. Each workstation shall be equipped with UPS.
8. with IT cable connecting with server cabinet inside computer server room.

D, Electronic room

1. Electronic room, installed four big UPS (70cm*70cm*180cm) for radiography system, and a Nuctech Panel (70cm*70cm*180cm), , that will be supplied and installed by Nuctech, is suggested with floor space of 15 sq. m;
2. Lighting, air-conditioning, CO2 fire extinguishers, standard office furniture for the room should also be built up, with accordance to local standards.
3. Illumination should be according to local standards.
4. Thunder lightning protection shall be built up according to local norm.
5. From Electricity room, total 60KVA power supply should be connected to the UPS.
6. The room should be equipped with cable trough for laying power cables connecting Nuctech Panel with four UPS; specification of 200mm*100mm is suggested. (If raised floor is used, power cables channel may go under the floor.)
7. 2*D100mm pipes is needed for connecting dragging chain in the Radiography building with Nuctech Panel in the Electronic Room. Steel wire should be put into the pipes for latterly wiring work.
8. 4*D100mm pipes is needed for connection Nuctech Panel in Electronic room with the cable trays surrounding the radiography building.
9. Cable trough from Nuctech Panel to operator room, specification of 100mm*75mm is suggested. (If raised floor is used, power cables channel may go under the floor.)

E, Electronic room

1. From Electricity room, total 60KVA power supply should be connected to the UPS (supplied by Nuctech) in Electronic room, with specification of 380V±5%, 50±1Hz, 3 phase & 5 lines, TN-S.

2. Power supply for all other system devices.
3. Power supply for illumination, maintenance and others devices in the scanning area should be separated from power supply of scanner and two shielding gates.

F, Spare parts room and technician room

1. Floor space of 20 sq. m;
2. A computer workstation (supplied by Nuctech) will be installed in the technician room.
3. All facilities should be built up, including lighting, air-conditioning, office furniture, etc, with accordance to local standards.
4. Illumination should be according to local standards.
5. Thunder lightening protection shall be built up according to local norm.
6. For each set of workstation, shall be staffed with 2 power sockets.
7. Each workstation shall be staffed network sockets with two RJ45 jacks, with IT cable connecting with server cabinet inside computer server room.

G, Driver's waiting room next to the radiography building

1. Public Address (supplied by Nuctech) will be installed in driver's waiting room.
2. All facilities should be built up, including lighting, air-conditioning, office furniture, etc, with accordance to local standards.
3. Illumination should be according to local standards.
4. Thunder lightening protection shall be built up according to local norm.
5. Shall be staffed with power sockets.
6. There should have one cable channel (min. 1*D100mm pipes) connecting to Computer server room for system communication.

H, Entry control room (Check-in)

1. Entry control room, equipped with a SCC workstation and its UPS, Driver's tagprinter, Document scanner, Network switches, PA, which will be supplied and installed by Nuctech, is suggested with floor space of 11 SQM (to be manned by 2 employees and used dually for 2 lanes);

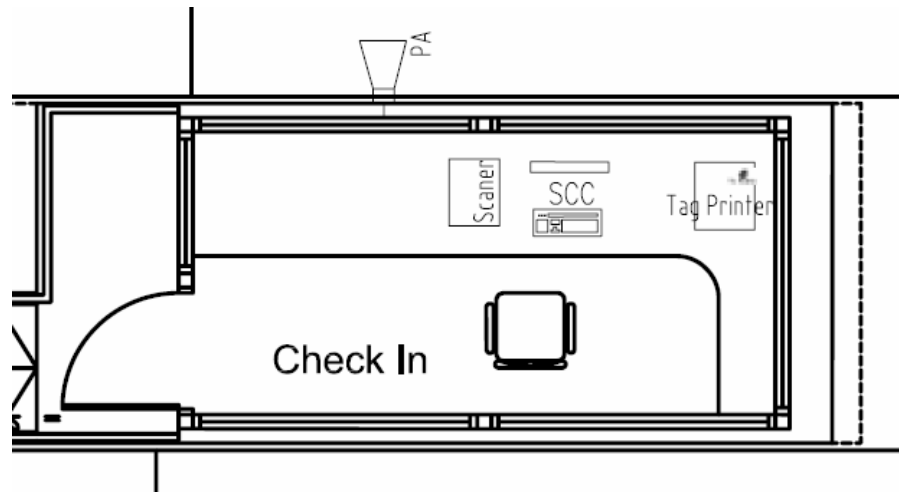

2. All facilities should be built up, including lighting, air-conditioning, power sockets and network sockets for system devices, cable trough surrounding the room, fire cabinet, office furniture, etc., with accordance to local standards.
3. Illumination should be according to local standards.
4. Thunder lightning protection shall be built up according to local norm.
5. Power and IT sockets for the designed operative devices as well as for service devices.
6. System connecting pipeline (min. 1*D100mm) for communication cable with Computer server room should be built up, equipped with fiber optical cable(Single mode, four cores).
7. The room should be equipped with cable trough for communication cables, specification of 100mm*50mm.
8. Each workstation shall be staffed network sockets with two RJ45 jacks.

I, Recheck office room

1. Recheck office is for operating manual check work stations, as well as equipped with one SCC workstation, driver's tag reader, network switches, and intercom, which will be supplied and installed by Nuctech.
2. All facilities should be built up, including lighting, air-conditioning, power sockets and network sockets for system devices, cable trough surrounding the

- room, fire cabinet, office furniture, etc, with accordance to local standards.
3. Illumination should be according to local standards.
 4. Thunder lightning protection shall be built up according to local norm.
 5. The room should be equipped with cable trough for communication cables, specification of 100mm*50mm.
 6. For each set of workstation, shall be staffed with 2 power sockets.
 7. Each workstation shall be staffed network sockets with two RJ45 jacks.
 8. System connecting pipelines (min. 1*D100mm) for communication cable with Computer server room should be built up, equipped with fiber optical cable (Single mode, four cores).

J, Driver's waiting room next to recheck building

1. One electronic information board (supplied and installed by Nuctech) will be installed on the wall of driver's waiting room.
2. There should have one cable channel (min. 1*D80mm pipes) connecting to Recheck office for system communication.
3. Public address will be installed by the contractor.

K, Check-out room

1. Entry control room with floor space of 8 sq. m, equipped with Check-out workstation and its UPS, Driver's tag reader, Network switches, PA, which will be supplied and installed by Nuctech.

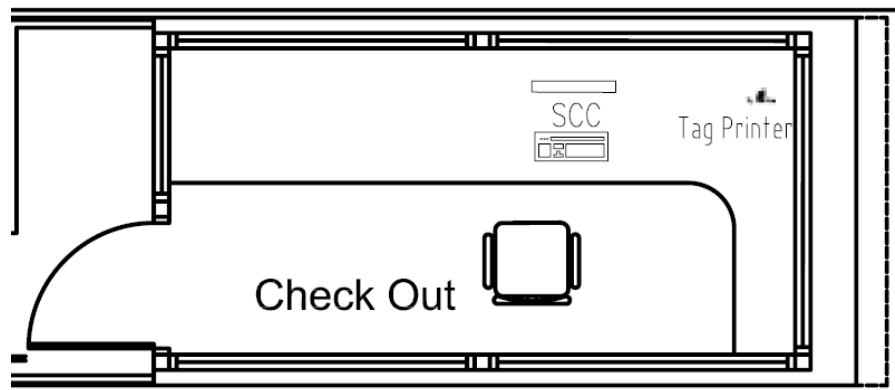

2. All facilities should be built up, including lighting, air-conditioning, power sockets and network sockets for system devices, cable trough surrounding the room, fire cabinet, office furniture, etc, with accordance to local standards.
3. Illumination should be according to local standards.
4. Thunder lightning protection shall be built up according to local norm.
5. The room should be equipped with cable trough for communication cables, specification of 100mm*50mm.
6. For each set of workstation, shall be staffed with 2 power sockets.

7. Each workstation shall be staffed network sockets with two RJ45 jacks.
8. System connecting pipelines (min. 1*D100mm) for communication cable with Computer server room should be built up, equipped with fiber optical cable (Single mode, four cores).

Principles and guidelines for construction works of system facilities installed on site

A, Electronic information board

1. Total four electronic information boards will be installed separately. One of which will be installed in front of Pre-scan Parking Lot; another one will be installed at the Pre-clearance Parking Lot; the third one will be installed at the Recheck building. The fourth one is a small screen installed on the wall of driver's waiting room in Recheck building.
2. Poles for supporting electronic boards should be supplied and installed.
3. Reinforcement concrete foundations for the poles (about 3 meters high) should be prepared.
4. System connecting pipelines (min. 1*D100mm) for communication cable with Computer server room should be built up separately.
5. Power supplies for the four boards are suggested to connect with nearest distribution box.

B, Traffic barrier

1. At the entrance gate, two sets of traffic barriers will be installed.
2. At the exit gate, two sets of traffic barriers will be installed.
3. Concrete bases 60cm*60cm, for installation of the barriers should be prepared. The top of the bases should be above the ground surface.
4. System connecting pipelines (min. 1*D100mm) for communication cable with Check in/out room should be built up separately.
5. Power supplies for the barriers are suggested to connect with nearest distribution box.

C, LPR

1. At entrance gate, two sets of LPR will be installed.
2. At exit gate, two sets of LPR will be installed.
3. In front of entrance of scanning hall, one set of LPR will be installed.
4. Concrete bases 30cm*30cm, for installation of poles of LPRs should be prepared. Top of the bases should be above the ground surface.
5. Poles for supporting LPRs should be supplied and installed.
6. System connecting pipelines (min. 1*D100mm) for communication cable with Check in/out room should be built up separately.
7. Power supplies for the barriers are suggested to connect with nearest distribution box.
8. Sensor that trigger LPR will be embedded on the ground.

Layout of entry control room

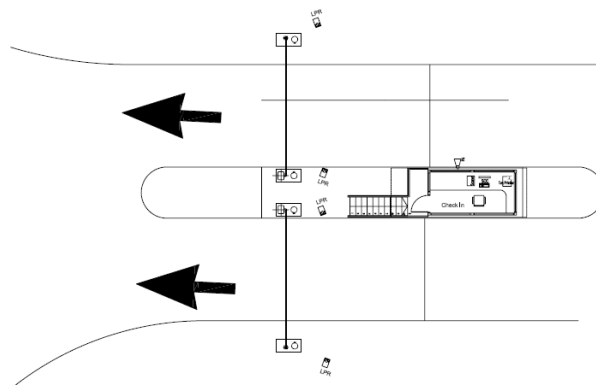

Layout of exit gate

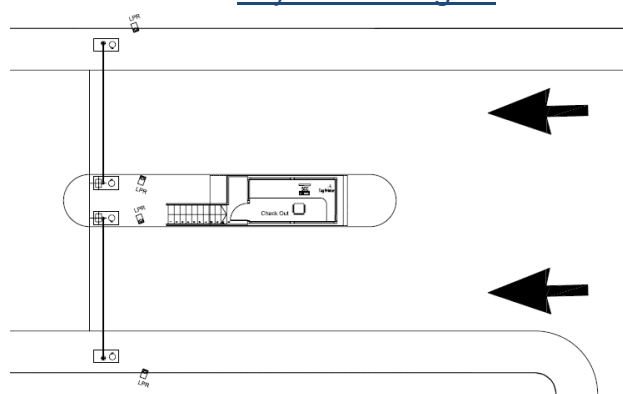

Principles and guidelines for the electricity plan of radiography system

**Note: This plan does not include electricity power consumption of non-radiography system, such as illumination, air-conditioning etc.*

Total electricity power requirement for whole radiography system including

1. Electricity for driving the scanner and system devices in scanning tunnel: 40KVA.
2. Electricity for driving the two shielding doors: 20KVA.
3. Electricity for system devices in operator room: 15KW.
4. Electricity for system devices in computer sever room : 5KW
5. Electricity for system devices in entry control station: 7KW.
6. Electricity for system devices in manual check area: 4KW
7. Electricity for system devices in exit gate: 6KW
8. Electricity for system devices (Information board) in pre-scan parking lot: 1KW
9. Electricity for system devices (Information board) in pre-clearance parking lot: 1KW
10. Electricity for system devices (Information board) in recheck building: 1KW
11. Electricity for system devices (Information board) in driver's waiting room next to recheck building: 500W

From MEB (main electricity board) of the site, one feeder of 60KVA should be connected with UPS (provided by Nuctech) in Electronic room.

Electricity Plan

